

In-Tank Rainwater System CMS C6A1 / C7A1

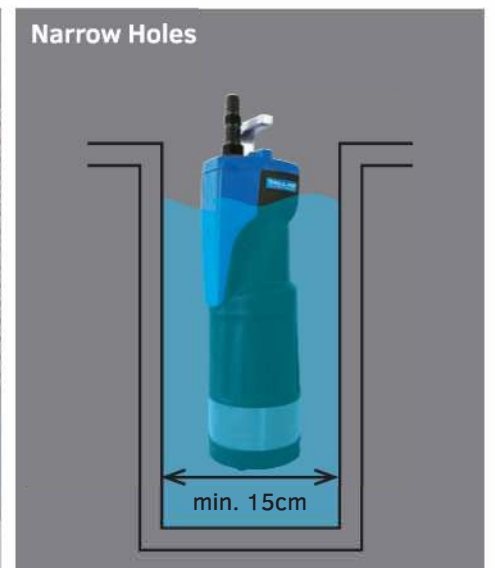

- Compact
- Integrated Automatic on/off
- Dry-run Protection
- Plug & Play
- 🇮🇹 Designed in Italy



Model	CMS C6A1	CMS C7A1	
Electrical data	P2 Pump consumption [W]	650	750
	Voltage [V]	1 ~ 230 AC	1 ~ 220-240 AC
	Frequency [Hz]	50	50
	Current [A]	3.8	4.8
	Capacitor μ F	12.5	12.5
	Capacitor Vc	450	450
Hydraulic data	Flow rate max. [l/min]	95	95
	Max. Pressure [Bar]	3.6	4.6
	Max. Head [m]	36	46
	Max. working pressure [bar]	6	6
	Max. Immersion depth [m]	12	12
	Min. submersion depth [cm]	12	12
	Switch-on pression [bar]	2.6+-0.2	2.6+-0.2
Range of use/materials	Length of Power Cable [m]	15	15
	Cable	H07 RNF	H07 RNF
	Pump International protection	IP 68	IP 68
	Insulation Class	B	B
	No. Impeller	3	4
	Liquid range Temperature [°C]	0 °C / +35 °C	0 °C / + 35 °C
	Dimension of particles [mm]	\varnothing 1	\varnothing 1
Dimensions / weight	L x W x H [mm]	155 x 150 x 500	155 x 150 x 525
	Ldm [mm]	39.5	39.5
	Hda [mm]	450	475.5
	DNM GAS	1" F	1" F
	Box Dimensions l x w x h [cm]	59 x 20.5 x 25.5	59 x 20.5 x 25.5
	Net/Gross Weight [kg]	10 / 12	10.8 / 12.8
	Quantity for pallet [no.]	32	32

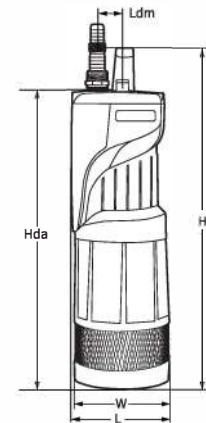
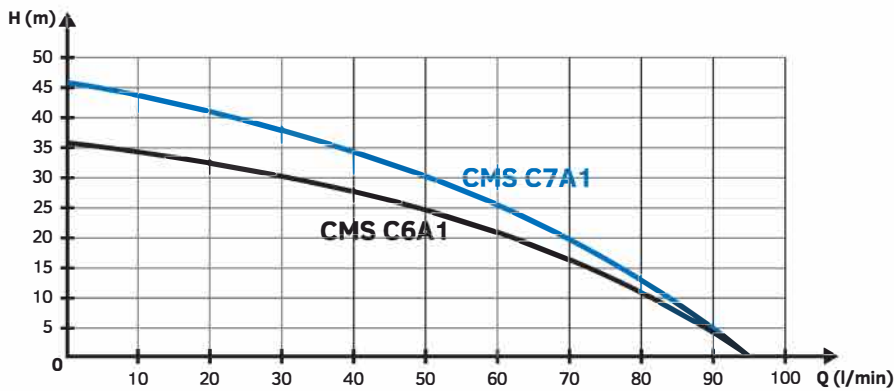

AcquaSaver

Max mains pressure 1050Kpa
 Max pump Pressure 1050 Kpa
 Max flow rate 200+ Lpm
 Rainwater inlet 1" BSP F (25mm)
 Mains water inlet 1" BSP F (25mm)
 Outlets 1" BSP F (25mm)
 Weight 1.9Kg

